



Standard Features

- Manual emergency lower system
- Platform swing gate
- Extended platform
- Foldable platform
- Multi-disc wet brake
- Manual brake release
- Pothole protection
- Non-marking tires
- AC power to platform
- Tilt alarm
- Buzzer
- Safety brackets
- Charging indicator
- Forklift pockets
- Diagnosis system
- Maintenance free battery
- Dual flashing beacon

Options Features

- Air line to platform
- Power socket to platform
- Platform work light
- Overload sensor
- Horn
- Anti-collision system
- Top limit protection auto-stop device
- Motion Alarm



XE-N SERIES

MODEL	XE65N	XE80N
Working height max H1	6.5 m	7.8 m
Platform height max H2	4.5 m	5.8 m
Platform height min	0.93 m	1.03 m
Length - Platform extension	0.9 m	
Lifting capacity	270 kg	230 kg
Lift capacity on the extension	115 kg	
Dimension of the platform BxGxA	1.64 x 0.75 x 1.1 m	
Platform length - extended K	2.54 m	
Platform skirting board height L	0.15 m	
Overall length and width ExF	1.93 x 0.77 m	
Height stowed D	2.04 m	2.13 m
Height - guardrails folded M	1.69 m	1.78 m
Wheelbase G	1.32 m	
Ground clearance H	0.06 m	
Ground clearance - deployed potholes	0.02 m	
Turning radius - inside	0.8 m	
Turning radius - outside	1.56 m	
Rising time / lowering time	11 / 8.5 s	14 / 11 s
Drive speed - stowed	3.8 km /h	
Drive speed - raised	0.7 km/h	
Gradeability	30%	
Tilt sensor - front to back	3°	
Tilt sensor - side to side	2°	
Driving motor power	Hydraulic / Electric	
Hydraulic tank capacity	15 L	
Tire size	356 x 114 x 254 mm	
Max. platform occupancy	2 pers	
Power source	4 x 6 V / 225 Ah	
Weight - ANSI/CSA Standard	1164 kg	1315 kg
- CE/AUS Standard	1235 kg	1490 kg

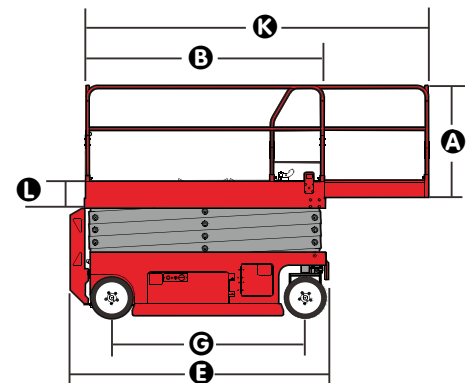
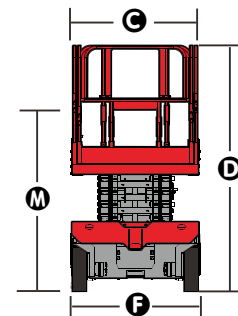
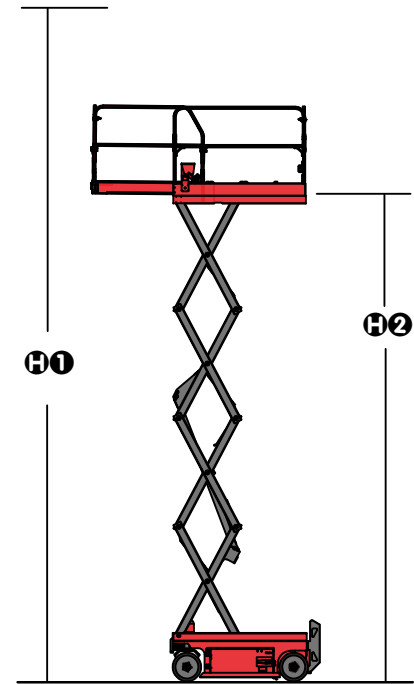

» Mantall provides user with both hydraulic drive (HD) and electrical drive (ED) walking modes, in order to meet the demands of different customers.